

Contents

Introduction.....	1
Supplies.....	2
Construction.....	3
Step 1 Hub assembly.....	3
1.1 Cut out one side of reel hub.....	3
1.2 Cut two slots on hub.....	4
1.3 Cut out stem at hub centre.....	5
1.4 Cut wooden brace.....	6
1.5 Wooden brace and plastic piece inserted into reel hub.....	7
1.6 Insert screw into hub to hold wooden brace in place.....	8
Step 2 Reel winder assembly.....	9
2.1 Drill hole from outer hub surface.....	9
2.2 Screw on wooden dowel handle.....	9
Step 3 Main handle assembly.....	10
3.1 Cut hole in metal and bend.....	10
3.2 Insert bolt.....	10
3.3 Attach main handle.....	11
3.4 Tighten handle nuts.....	12
Step 4 PVC cap assembly.....	13
4.1 Drill holes into PVC cap.....	13
4.2 Insert meter into cap.....	16
4.3 Insert adhesive battery strip.....	17
4.4 Insert battery.....	17
4.5 Feed battery wire through cap hole.....	18
4.6 Meter screws into PVC cap screw holes.....	19
4.7 Insert toggle switch.....	20
Step 5 Wiring.....	21
5.1 Attach antennae ribbon to hub.....	22
5.2 Solder one antennae wire to negative (black) battery wire.....	23
5.3 Solder other antennae wire to positive (red) extension wire.....	23
5.4 Attach antennae positive (red) extension terminal clip to ammeter with screw.....	24
5.5 Solder positive (red) battery wire to toggle switch.....	24
5.6 Attach resistor wire from positive ammeter terminal to toggle switch.....	25
5.7 Test that the meter and ribbon work.....	25
5.8 Insert assembled meter cap into reel hub.....	26
Step 6 Ribbon assembly.....	27
6.1 Wrap electrical tape around reel hub to cover screw heads.....	27
6.2 Wind antennae ribbon onto reel.....	27
6.3 Attach copper sheathing onto antennae ribbon end.....	28
6.4 Mark antennae ribbon for length.....	29
Step 7 Completed water-level meter.....	30

Figures

Figure 1. Supplies for building water-level measuring meter.	2
Figure 2. Centre of reel hub to be removed and cut.	3
Figure 3. Cut across the spokes.....	3
Figure 4. Front view of completed reel.....	4
Figure 5. Drill 4 3-mm holes in the drum reel to cut centre hub and antennae ribbon access.	4
Figure 6. Saw through centre bearing.....	5
Figure 7. Wooden brace.	6
Figure 8. Cut wooden brace.	6
Figure 9. Insert wooden brace into reel hub.	7
Figure 10. Wooden brace and plastic reel end-piece inside reel hub.	8
Figure 11. Insert screw into hub and wooden brace.....	8
Figure 12. Inserting gutter bolt.	9
Figure 13. Screw on the tapped wooden dowel handle.....	9
Figure 14. Insert handle bolt.	10
Figure 15. Attach washer and nut to handle bolt.....	10
Figure 16. Attach handle.....	11
Figure 17. Attach handle nut.....	11
Figure 18. Tighten handle nut.....	12
Figure 19. Meter assembly.....	13
Figure 20. Centre cut from PVC cap.	13
Figure 21. Holes drilled in PVC cap.....	14
Figure 22. Mark cap and reel for later realignment.	15
Figure 23. PVC cap and reel aligned.....	15
Figure 24. Inserting meter into PVC cap.	16
Figure 25. Meter set into cap and reel.....	16
Figure 26. Attach adhesive strip.	17
Figure 27. Attach battery to adhesive strip.	17
Figure 28. Battery wires through cap hole.	18
Figure 29. Meter inside PVC cap.	18
Figure 30. Screws nuts onto meter screws with flat and spring washers.....	19
Figure 31. Meter secured to cap with screws and nuts.	19
Figure 32. Attach toggle switch.	20
Figure 33. Switch in place.....	20
Figure 34. Meter wiring.	21
Figure 35. Put antennae ribbon into reel slot.....	22
Figure 36. Knot antennae ribbon inside reel.....	22
Figure 37. Solder one wire to negative battery wire.....	23
Figure 38. Solder other antennae wire red extension to negative ammeter terminal clip.	23
Figure 39. Attach positive terminal clip to ammeter with screw.....	24
Figure 40. Solder positive (red) battery wire to toggle switch.	24
Figure 41. Attach resistor wire from positive meter to toggle.....	25
Figure 42. Meter cap into reel hub.	26
Figure 43. Screw Meter cap to reel.	26
Figure 44. Wrap antennae ribbon around reel hub.....	27
Figure 45. Wrapping antennae ribbon around hub.....	27
Figure 46. Attach copper sheath to antennae ribbon end.	28
Figure 47. Wrap electrical tape around copper sheath.....	28
Figure 48. Mark antennae ribbon length increments.....	29
Figure 49. Marked antennae ribbon.....	29
Figure 50. Completed water-level meter.....	30

Introduction

Well owners depend on ground water but typically don't know how to monitor it. Water level measurements can tell a well owner if their water is secure or if their well is developing a problem. More specifically, water-level measurements can determine the effects of neighbours pumping their wells and the difference between winter recharge levels and summer lows.

This report gives instructions on how to build a water-level measuring meter. Instructions may be modified to suit the person building it or who has greater knowledge in electronics and construction. Brand names used in this report are not endorsements. Sketches are not to scale but are given to show general construction.

Supplies

Necessary supplies are given in Table 1 and some are shown in Figure 1. The PVC cap, wooden brace, and fence reel centre shown in Figure 1 (bottom centre) were pre-cut. The metal handle shown at the right was pre-bent.

Table 1. Supplies

In Figure 1 or as noted	Part	Number	Supplier
A	electric fence reel (Stafix)	1	rural supply agents
B	100-mm diameter 12-mm-thick plywood disc (Figure 7 and Figure 8 shows correct cuts)	1	lumber
Figure 35	TV antennae ribbon (50 m or as well-depth required)	1	electronics store
C	0--1 ma ammeter	1	electronics store
D	9-volt carbon/alkaline battery type PP3	1	electronics store
Figure 29	battery connector cap and wires to fit PP3-type battery	1	electronics store
E	12 mm x 100 mm bolt with 2 nuts & 2 flat washers (galvanised steel, brass, or stainless steel)	1	hardware
G	10-cm PVC end cap	1	hardware
Figure 32	2k2 0.5-watt resistor	1	electronics store
H	toggle switch (single pole single throw--SPST)	1	electronics store
I	33 mm of 12-mm dowel (hard wood, PVC, or metal)	1	lumber
Figure 46	100-mm long, 6-mm-inside-diameter copper tube	1	plumbing
Figure 26	double sided adhesive foam pad	1	stationery store
Figure 11	5 mm x 12 mm screws, self-tapping type "ab" pan head	4	hardware
J , Figure 11	4 mm x 12 mm wood screws with counter sunk head	4	hardware
K , Figure 30	4 mm x 10 mm screws, self-tapping type "ab" pan head	4	hardware
L , Figure 12	3/16 x 1-inch gutter bolt & nut	1	hardware
M , Figure 12	5 mm flat washers	2	hardware
N	310 mm of 1.5-inch x 1/8-in. flat mild steel	1	steel fabricators
section 1.6	Araldite glue	1	hardware
section 1.4	paint	1	hardware

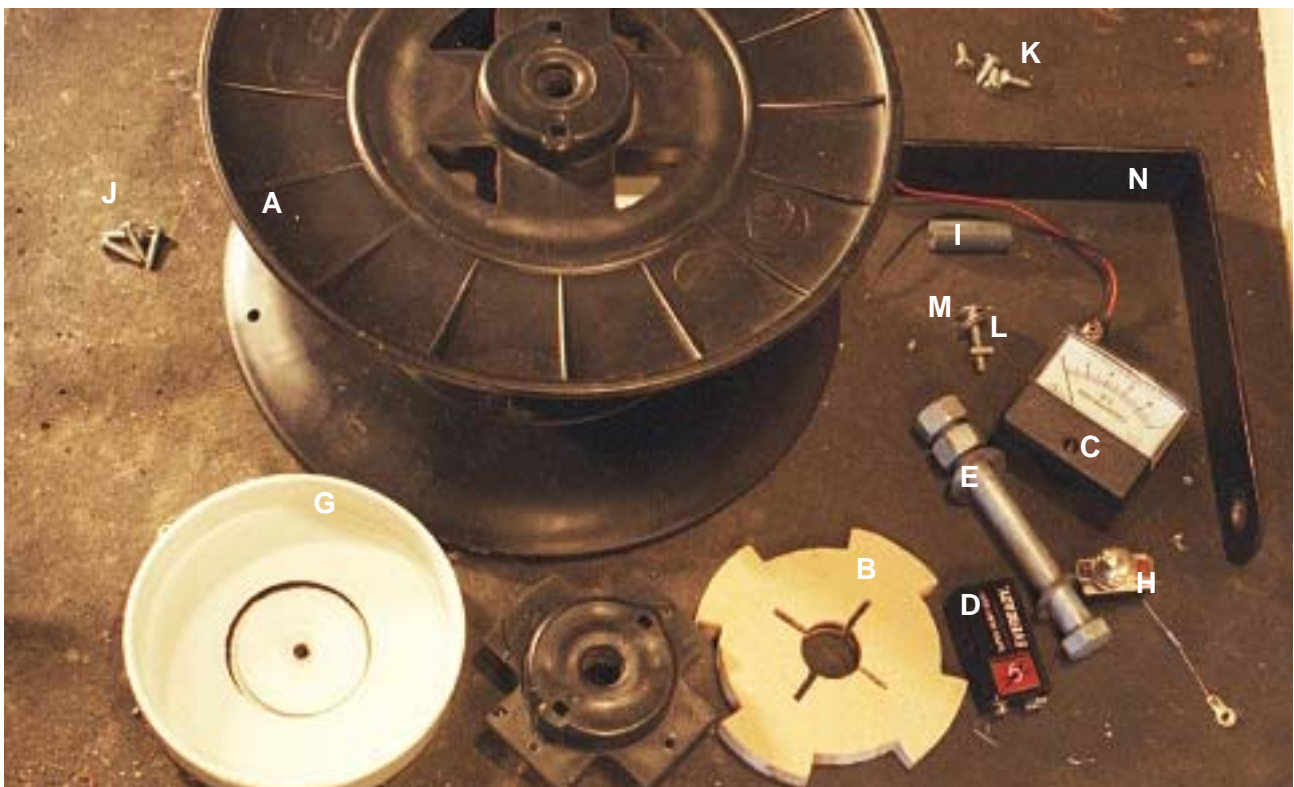
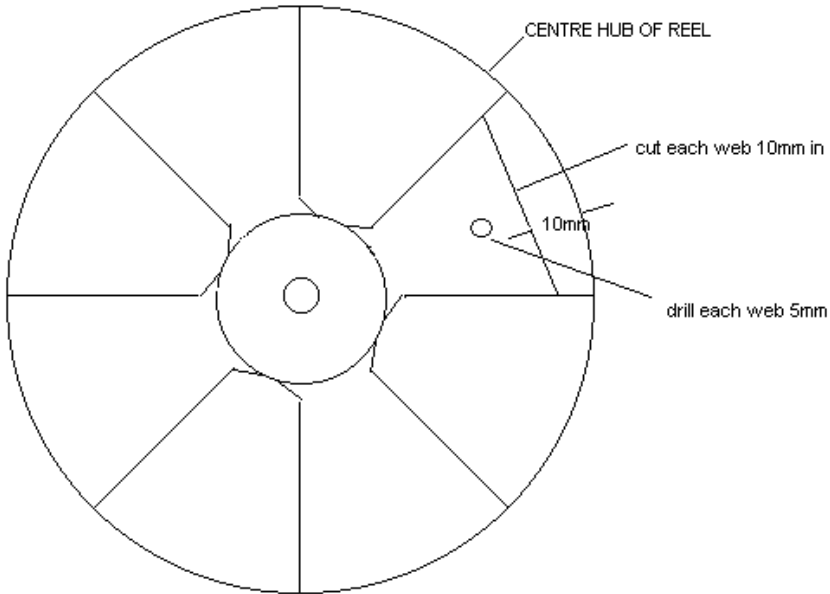

Figure 1. Supplies for building water-level measuring meter.

Construction

Step 1 Hub assembly

1.1 Cut out one side of reel hub



On the side of the reel that the ammeter is to be fitted, cut across the four spokes and around the centre hub as shown in Figure 2 and Figure 3.

Figure 2. Centre of reel hub to be removed and cut.



Figure 3. Cut across the spokes.

1.2 Cut two slots on hub

Drill 4 3-mm holes, side by side, in the reel drum, 68 mm from the “to-be” handle side. See Figure 4 and Figure 5. Slot the holes with a hacksaw to have one opening. Drill and complete a second 10-mm-long slot through the reel hub, 20 mm in from the side that the meter is to be fitted-- as shown at the right in Figure 4 and Figure 5.

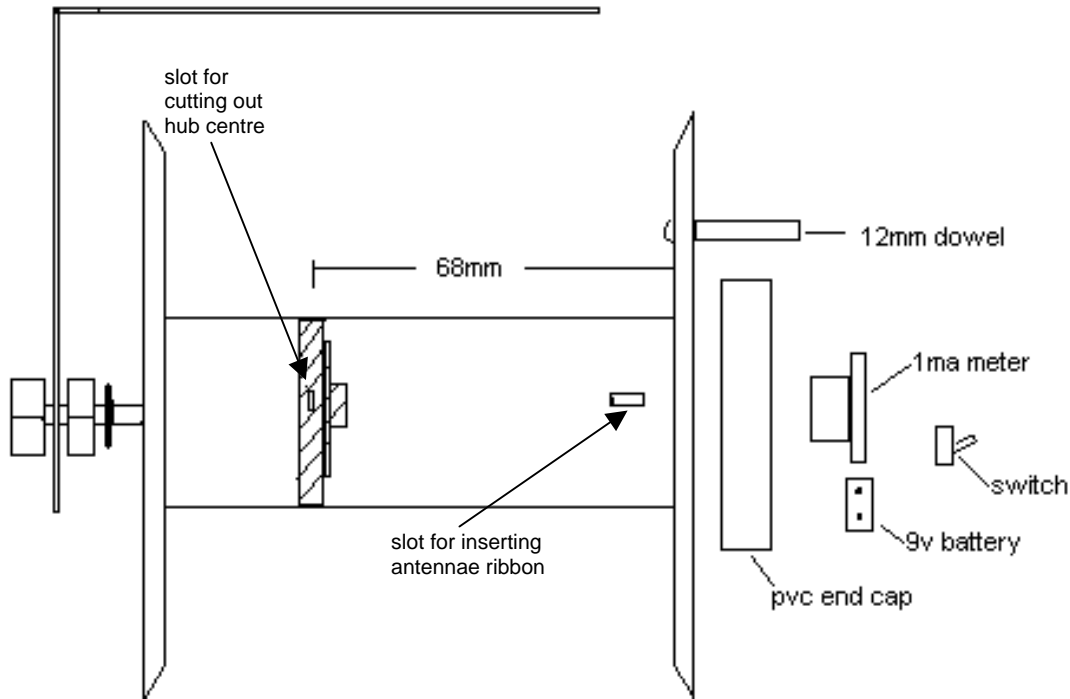

Figure 4. Front view of completed reel.

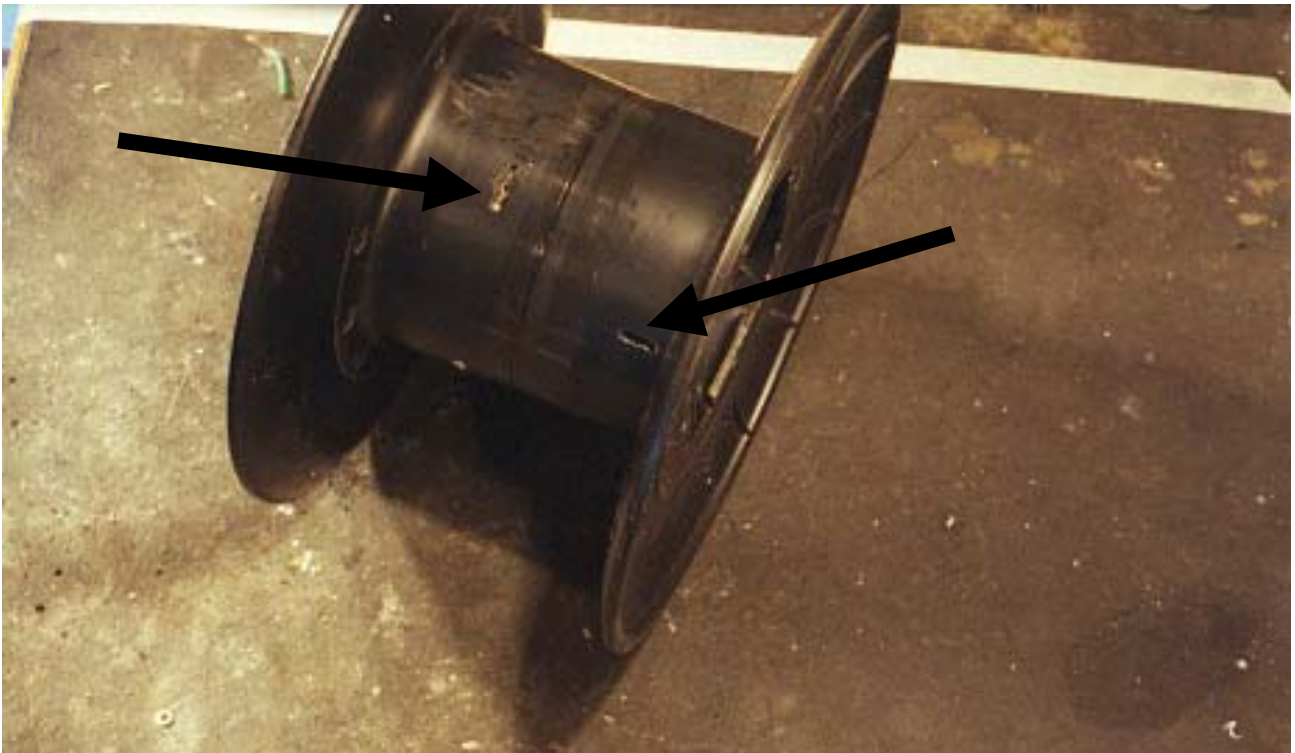

Figure 5. Drill 4 3-mm holes in the drum reel to cut centre hub and antennae ribbon access.

1.3 *Cut out stem at hub centre*

Use a hacksaw blade to saw through the slot and cut through the centre stem. This will then allow for removing centre section that needs to later be braced and relocated inside the reel.

After the centre is removed, cut a further 65 mm from the stem. This will allow enough clearance to fit the meter and switch.

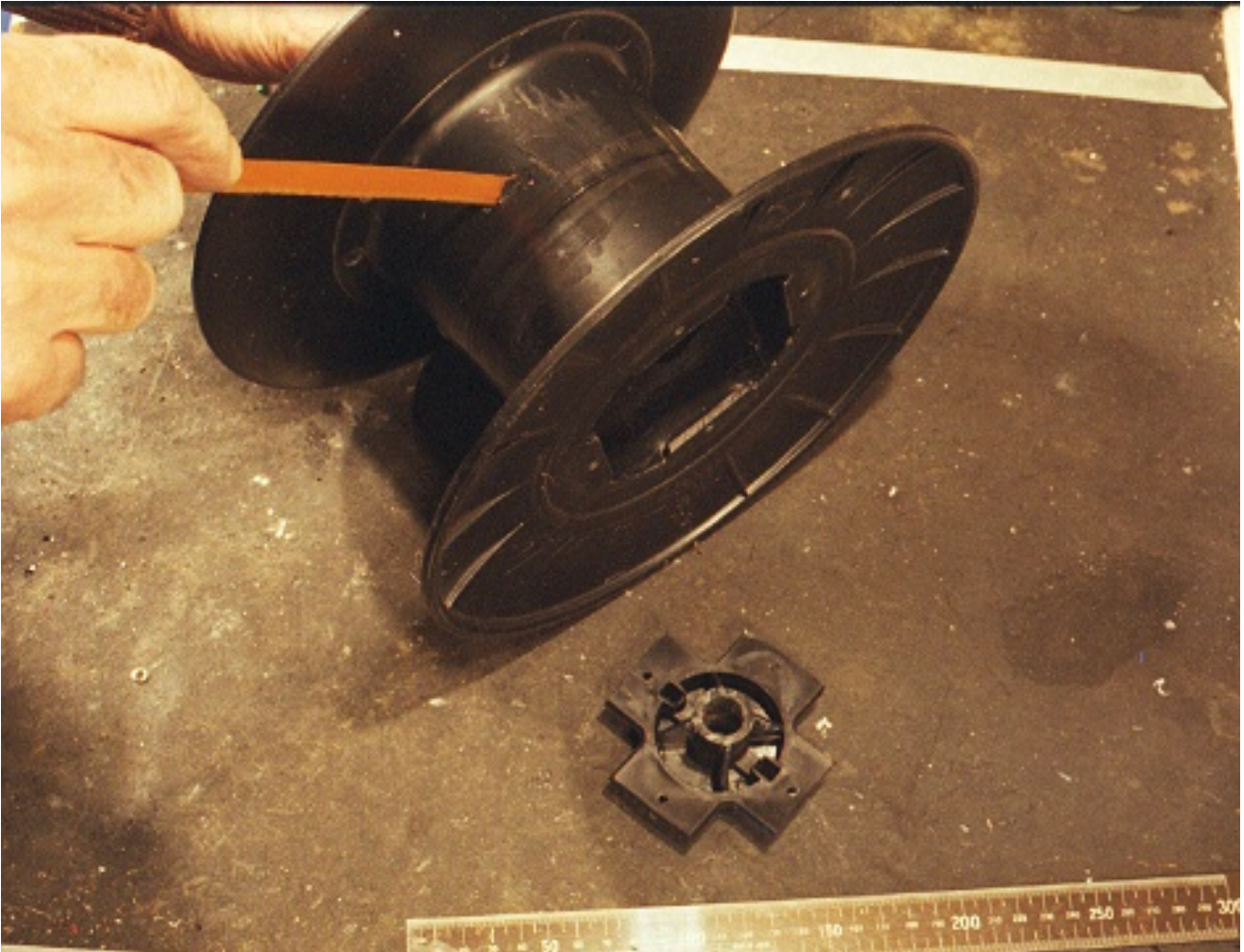

Figure 6. Saw through centre bearing.

1.4 Cut wooden brace

From a piece of approximately 12-mm plywood or similar board, cut a 100-mm-diameter disc. Drill a 22-mm hole through the disc centre. If the section that has been removed from the reel has strengthening gussets moulded in it, then it will be necessary to cut slots as shown in Figure 7 and Figure 8. Fit the two pieces together to be sure that they fit snugly. Cut the sections out of the outer circumference to later help place the assembled bearing hub back inside the reel drum. Check that the disc fits snugly inside the hub section of the reel. Apply liberal undercoat or sealer to the wooden disc to prevent water getting in to the wood.

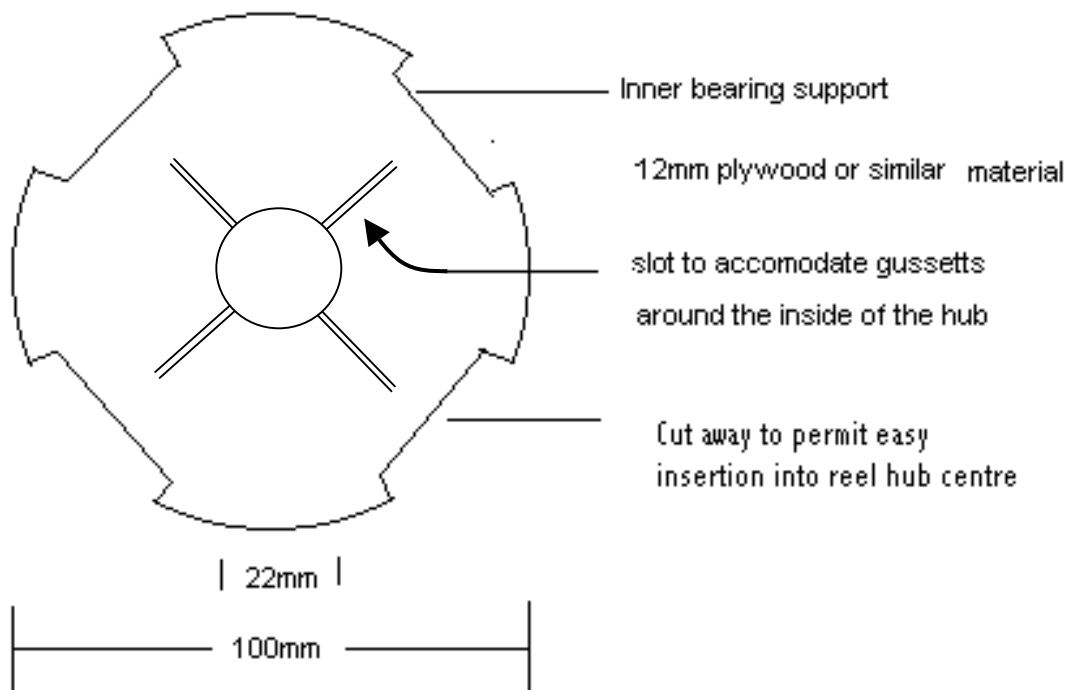

Figure 7. Wooden brace.

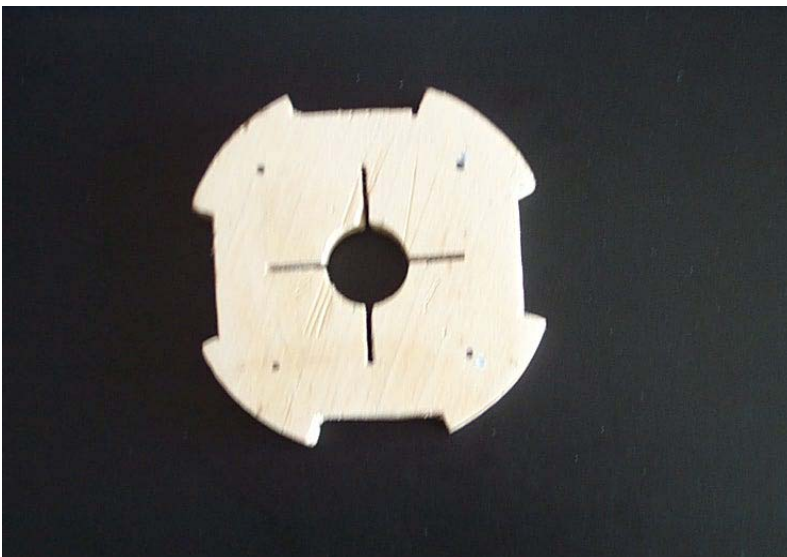

Figure 8. Cut wooden brace.

1.5 *Wooden brace and plastic piece inserted into reel hub*

Insert wood disc inside the reel shown in Figure 9. Fit the plastic end piece to the wood disc with the 5 mm x 12 mm self-tapping screws.



Figure 9. Insert wooden brace into reel hub.

1.6 Insert screw into hub to hold wooden brace in place.

Temporarily insert the 12 mm x 100 mm bolt through the assembled end piece wood disc and reel centre. Rotate the wood-braced support so that a screw passing through the slot in the hub (Figure 4 and Figure 5) centres on one of the wooden sections in touch with the inside of the hub. Drill 3 more holes equally spaced around the circumference of the hub. Countersink each hole to allow the heads to be flush with the hub surface. Identify the position of the disc to the reel. Remove the bolt and support to enable enough Araldite glue to liberally coat the 4 portions of the wood disk that will contact the inside hub. Apply the Araldite to the outer sections of the wood and reassemble to the previously identified position (Figure 10) and fit the screws (Figure 11) into the wood support and cover the heads with insulations tape wrapped around the hub exterior (see Figure 45).

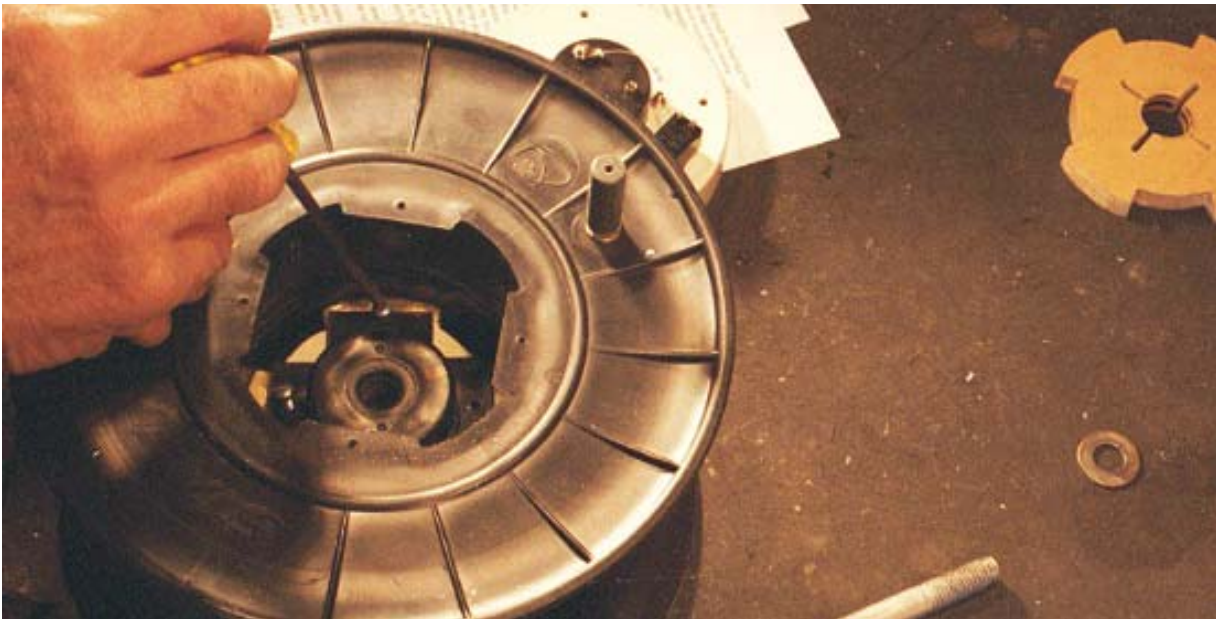

Figure 10. Wooden brace and plastic reel end-piece inside reel hub.



Figure 11. Insert screw into hub and wooden brace.

Step 2 Reel winder assembly

2.1 Drill hole from outer hub surface

Drill a 5-mm hole in the side of the reel as in Figure 4 (labelled with “12 mm dowel”), 89 mm from the hub centre. Drill and tap (hole access for a screw thread) the 12-mm dowel 3/16-in. (Whitworth) to suit the gutter bolt thread. Put a 5-mm flat washer on the gutter bolt and insert through the 5 mm hole. Put on the other flat washer, add nut and tighten.



Figure 12. Inserting gutter bolt.

2.2 Screw on wooden dowel handle

Screw the dowel on to the gutter bolt.



Figure 13. Screw on the tapped wooden dowel handle.

Step 3 Main handle assembly

3.1 *Cut hole in metal and bend*

Drill a 12-mm hole in the straight metal piece, 20 mm on centre from one end. Bend at right angles, 155 mm further from the drilled hole as shown at the right side of Figure 1 and upper left of Figure 4.

3.2 *Insert bolt*

Put a 12-mm flat washer on the 12 mm bolt and place the bolt through the bearing from the side that the meter is to be fitted.



Figure 14. Insert handle bolt.

Put a 12-mm flat washer and nut on the threaded end of the bolt. Tighten nut.



Figure 15. Attach washer and nut to handle bolt.

3.3 Attach main handle

Slip the handle on and the second nut.



Figure 16. Attach handle.



Figure 17. Attach handle nut.

3.4 Tighten handle nuts

Adjust the end clearance of the reel so that it doesn't drag when turning the reel.



Figure 18. Tighten handle nut.

Step 4 PVC cap assembly

The suggested orientation of meter assembly is shown Figure 19 both other options are possible.

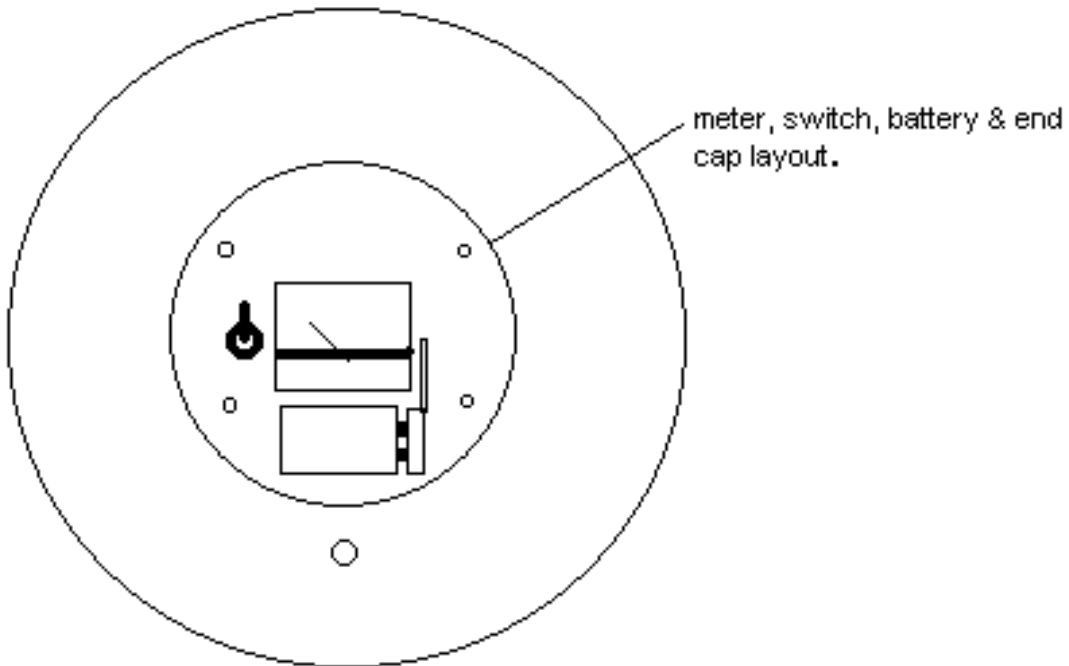

Figure 19. Meter assembly.

4.1 Drill holes into PVC cap

1. Drill out PVC cap centre for mounting the ammeter (Figure 20). Hole size to accommodate the meter body.
2. Drill 4 4 x 3-mm holes for attaching ammeter screws (Figure 21) for steps 2-5.
3. Drill 4 4-mm evenly spaced holes around the PVC cap, 8 mm in from inside the cap rim. Align the 4 holes with the centre of the reel spokes and drill a 2-mm pilot hole through each.
4. Drill 3-mm hole for battery wires.
5. Drill hole for toggle switch, diameter to accommodate switch.

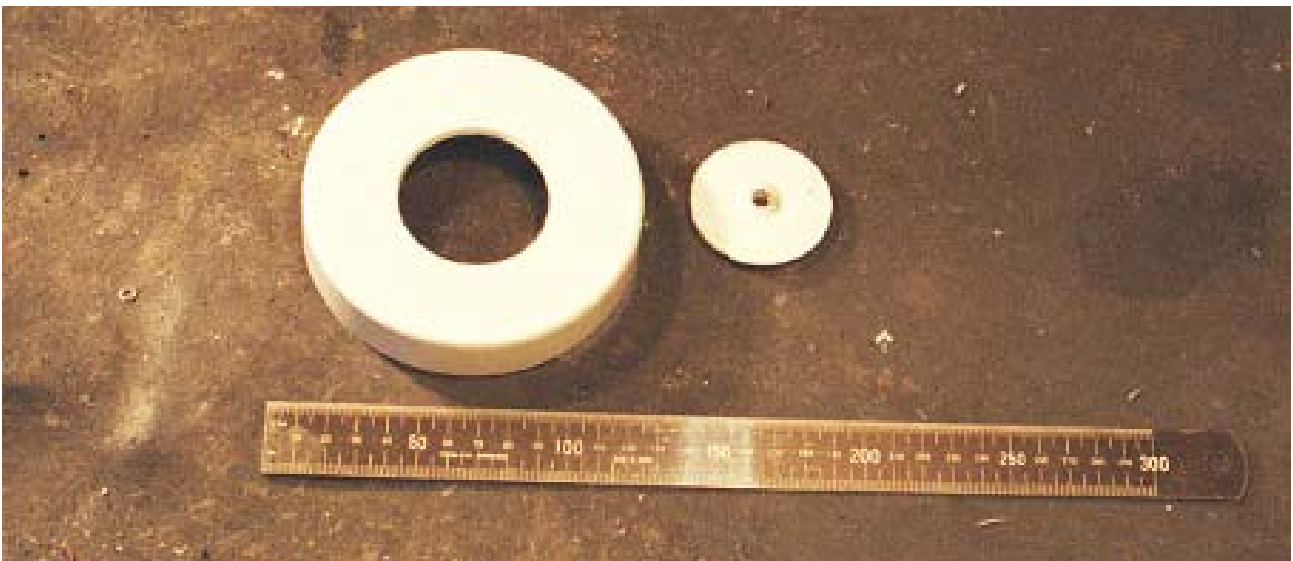

Figure 20. Centre cut from PVC cap.

When completed, drilled holes should as shown in Figure 21.

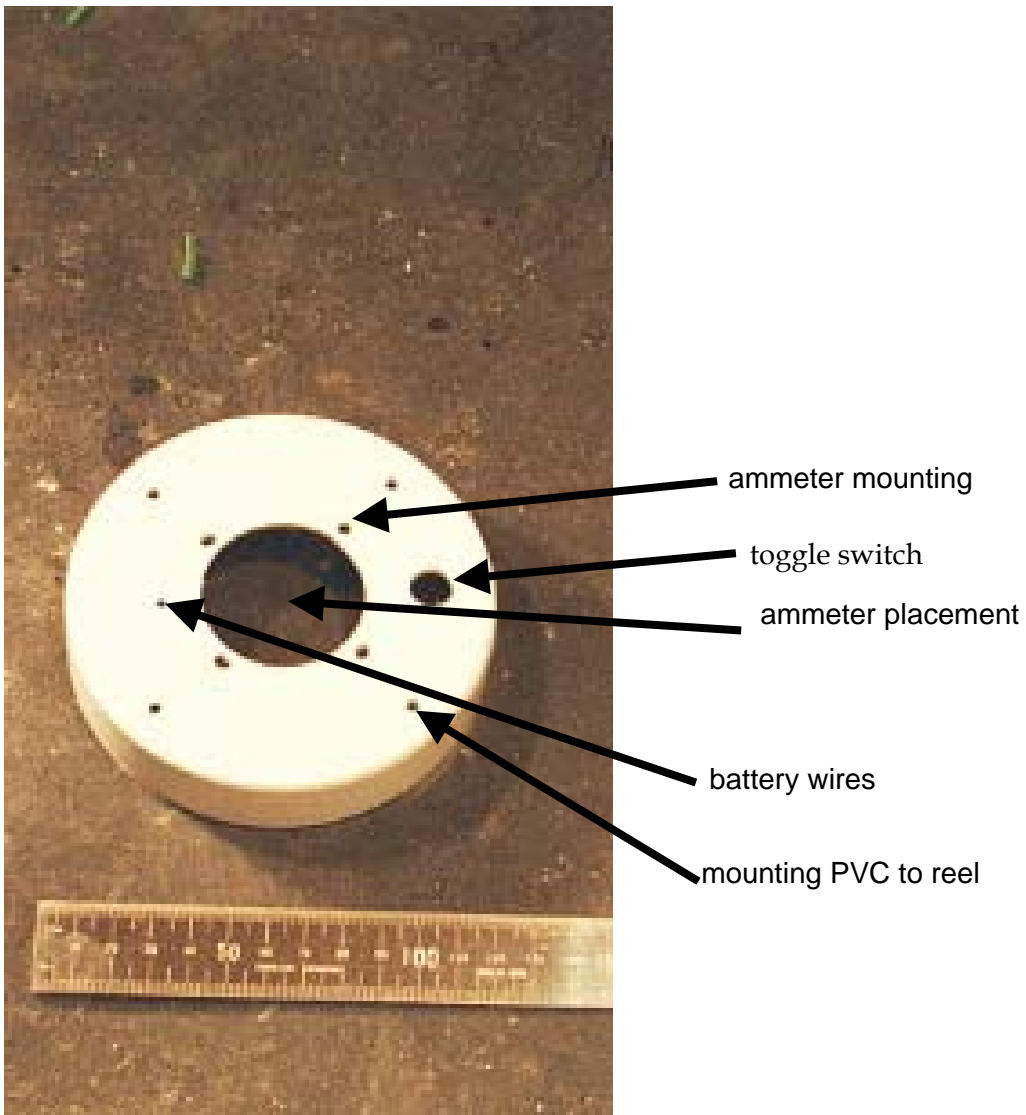

Figure 21. Holes drilled in PVC cap.

It is a useful idea to mark the cap in relation to side of the reel to more easily reassemble the two components (Figure 22 and Figure 23).



Figure 22. Mark cap and reel for later realignment.

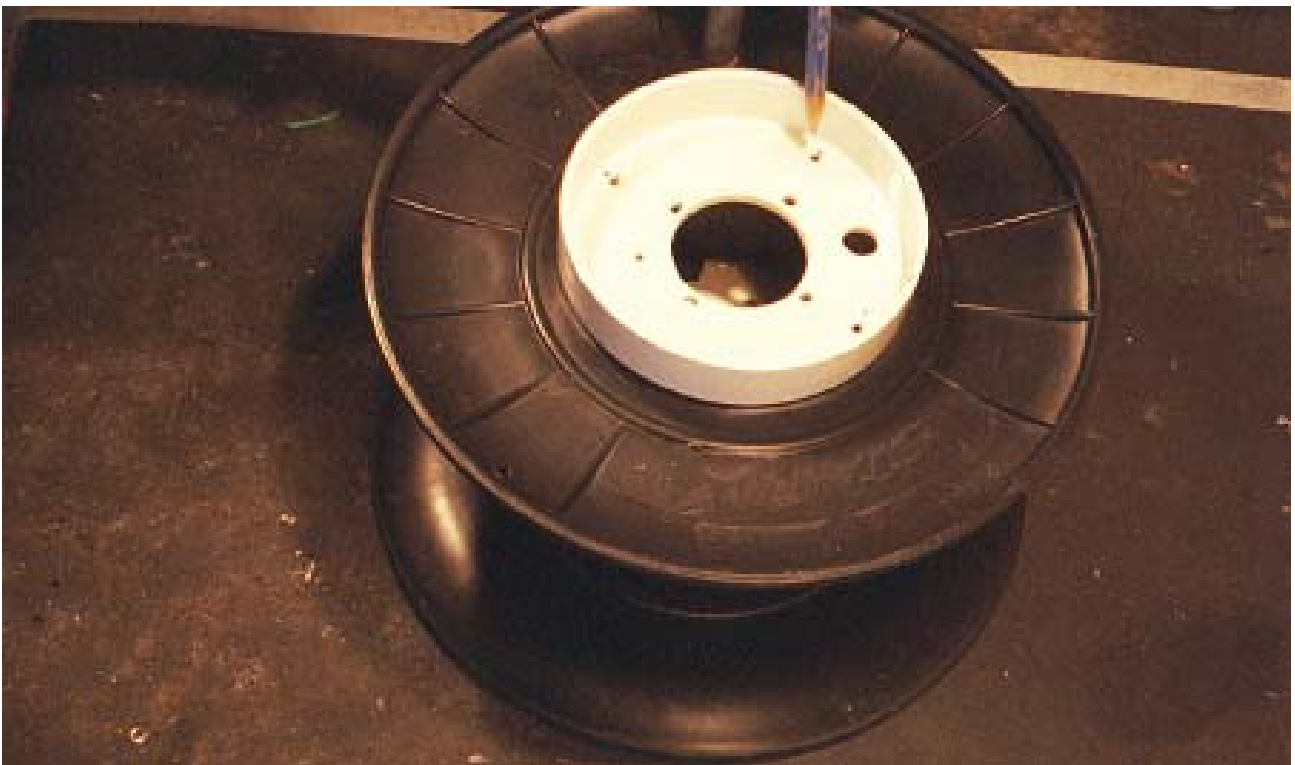

Figure 23. PVC cap and reel aligned.

4.2 *Insert meter into cap*

Fasten the meter into the inside of the cap.



Figure 24. Inserting meter into PVC cap.



Figure 25. Meter set into cap and reel.

4.3 Insert adhesive battery strip

Attach a double-adhesive-sided foam tape for later attaching a 9-volt battery. If the meter size is too large, then the adhesive and batter may need to be attached inside the hub.



Figure 26. Attach adhesive strip.

4.4 Insert battery

Attach a 9-volt battery between the face of the meter and the outer rim of the PVC cap



Figure 27. Attach battery to adhesive strip.

4.5 Feed battery wire through cap hole



Figure 28. Battery wires through cap hole.



Figure 29. Meter inside PVC cap.

4.6 Meter screws into PVC cap screw holes.



Figure 30. Screws nuts onto meter screws with flat and spring washers.

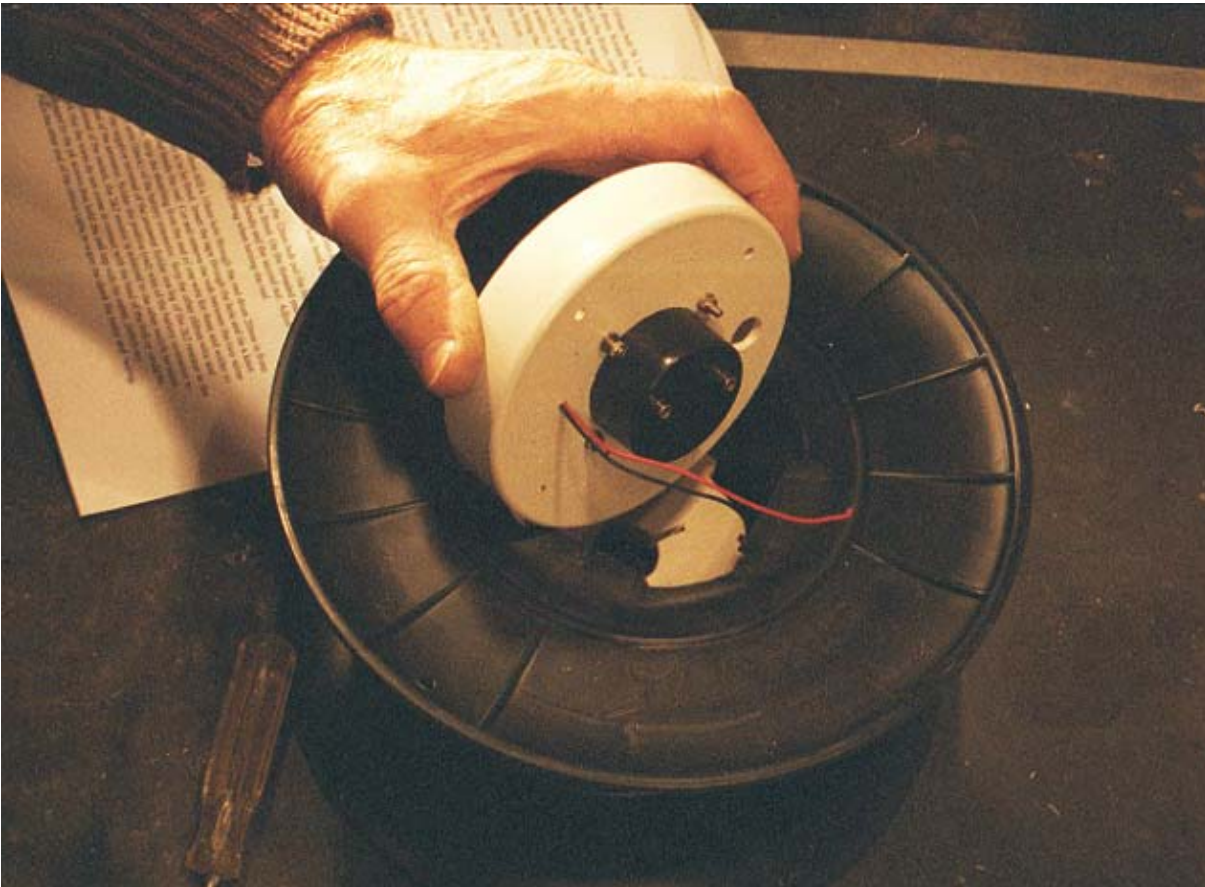

Figure 31. Meter secured to cap with screws and nuts.

4.7 Insert toggle switch

Meter size will also determine the fitting of a switch. Switch shown has resistor wire previously attached. The switch position will be determined by needing to be positioned between the spokes and the meter.



Figure 32. Attach toggle switch.



Figure 33. Switch in place.

Step 5 Wiring

The following shows the general meter wiring.

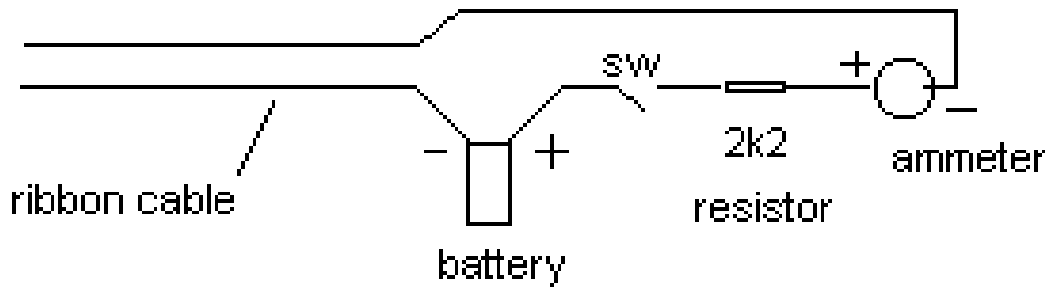

Figure 34. Meter wiring.

Note that some of the following photos are out of wiring sequence, though the critical parts are indicated. For example, Figure 41 shows the resistor wire already soldered to the toggle switch and lacking the wiring noted in the previous step.

5.1 *Attach antennae ribbon to hub*

Insert the ribbon through the previously cut slot (section 1.2) and tie a knot 125 mm from the end inside the reel. Cut and remove the web between the two wires for about 90 mm.



Figure 35. Put antennae ribbon into reel slot.



Figure 36. Knot antennae ribbon inside reel.

5.2 Solder one antennae wire to negative (black) battery wire

Strip 4 mm of sheathing from the end of one wire and solder to the negative (black) battery wire. Insulate joint with insulation tape.

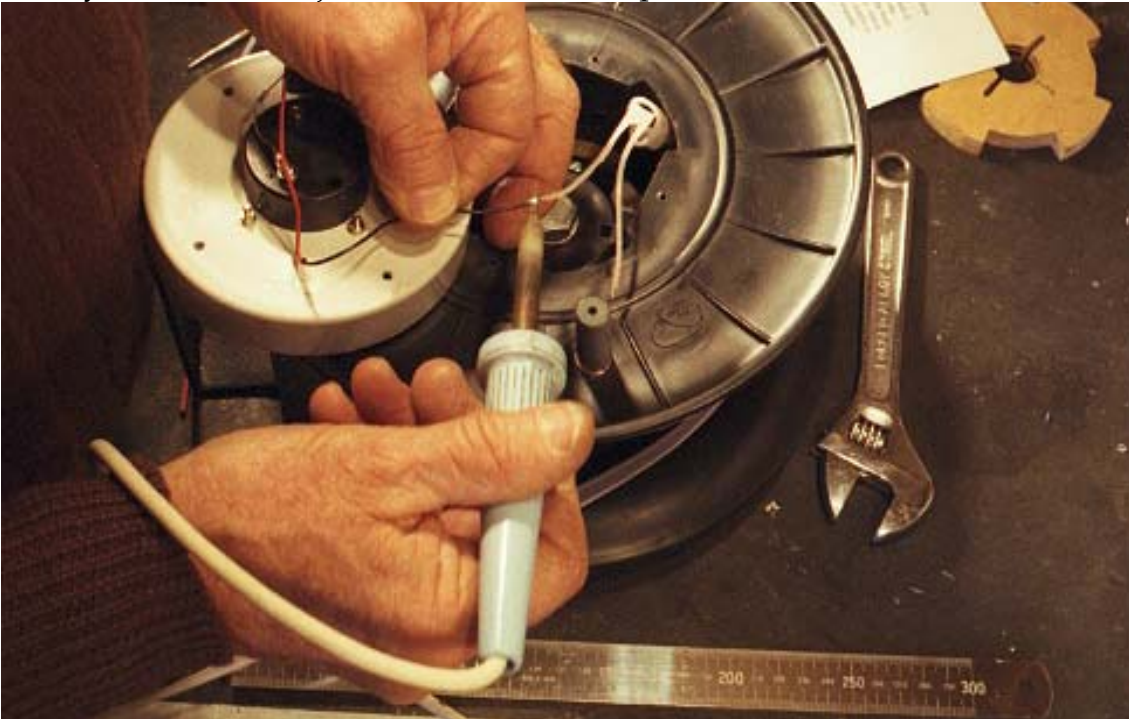

Figure 37. Solder one wire to negative battery wire.

5.3 Solder other antennae wire to positive (red) extension wire.

Solder other antennae wire to a red extension wire and insulate with insulation tape. Fit negative terminal clip to free end of red wire. Solder one leg of the 2k2 resistor to terminal clip and screw to positive ammeter terminal. Solder other end of resistor to the switch.

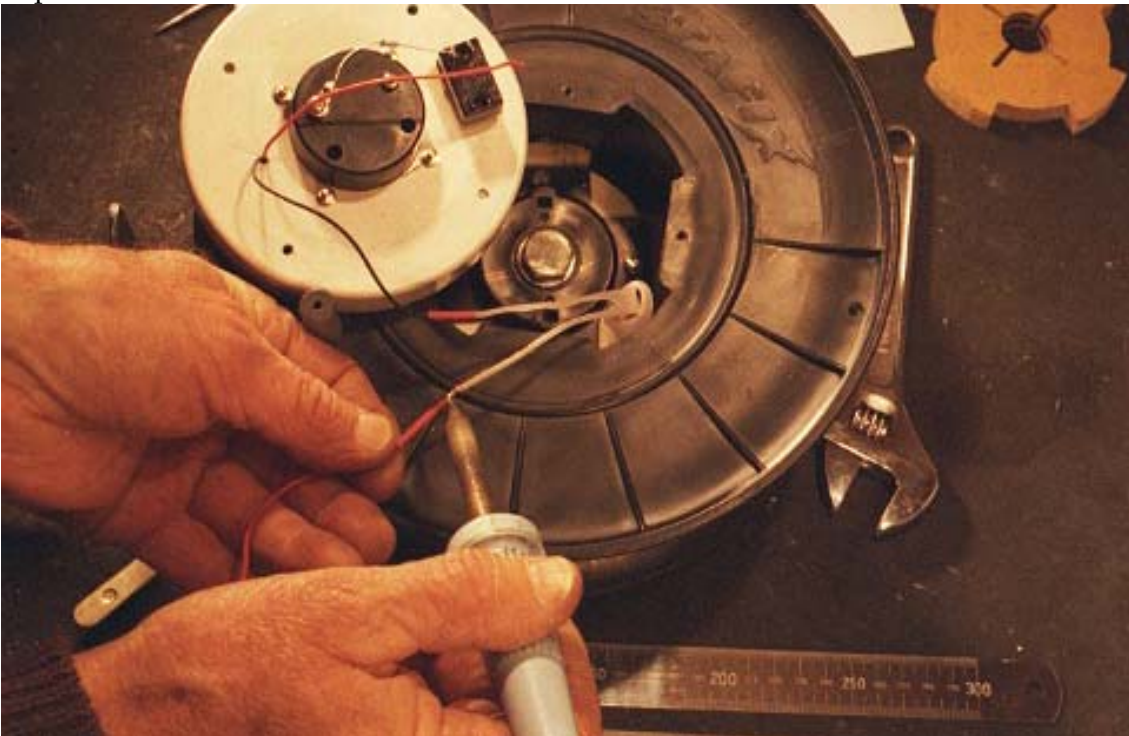

Figure 38. Solder other antennae wire red extension to negative ammeter terminal clip.

5.4 *Attach antennae positive (red) extension terminal clip to ammeter with screw.*

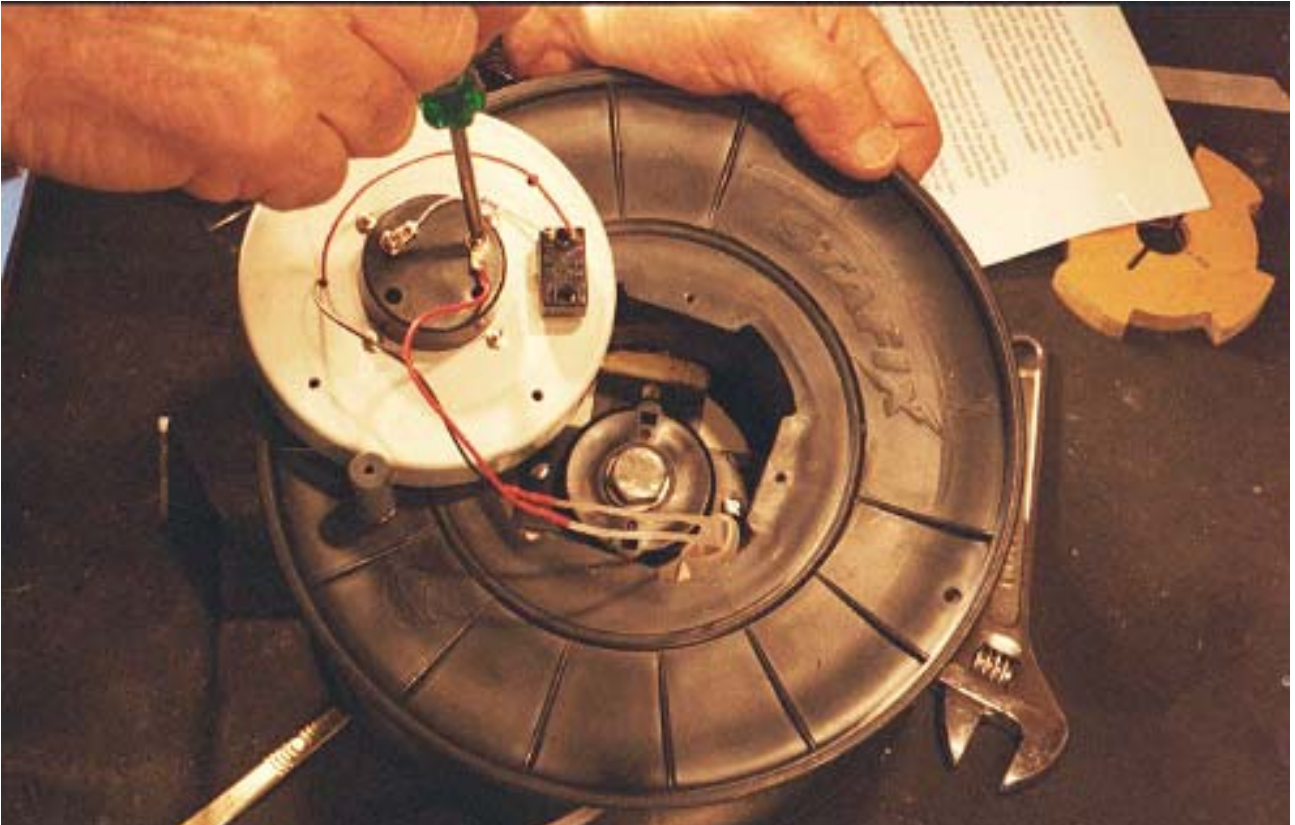

Figure 39. Attach positive terminal clip to ammeter with screw.

5.5 *Solder positive (red) battery wire to toggle switch.*



Figure 40. Solder positive (red) battery wire to toggle switch.

5.6 *Attach resister wire from positive ammeter terminal to toggle switch.*

Attach 2K2 resister wire terminal clip to positive ammeter terminal and solder other end to remaining toggle switch terminal.

Check that the wires do not contact the bolt head or damaged by the self-tapping screws that hold the end cap with the meter, switch, and such.

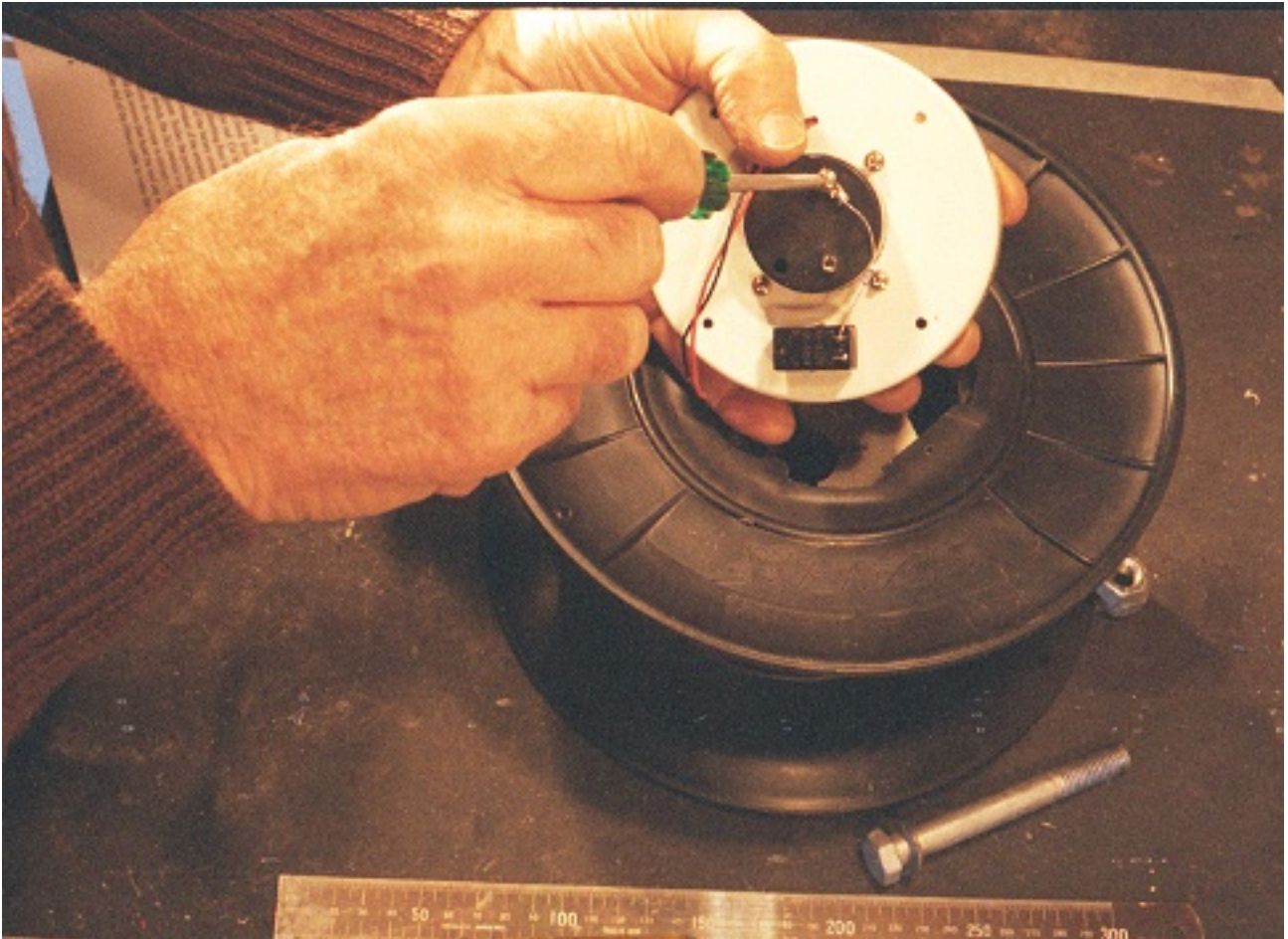

Figure 41. Attach resister wire from positive meter to toggle.

5.7 *Test that the meter and ribbon work.*

Turn switch on and place other end of the antennae ribbon in water to ensure it registers. Water completes the electrical connection between the two antennae wires.

5.8 Insert assembled meter cap into reel hub

Screw the end cap into place with 4 4-mm x 10-mm self-tapping screws.

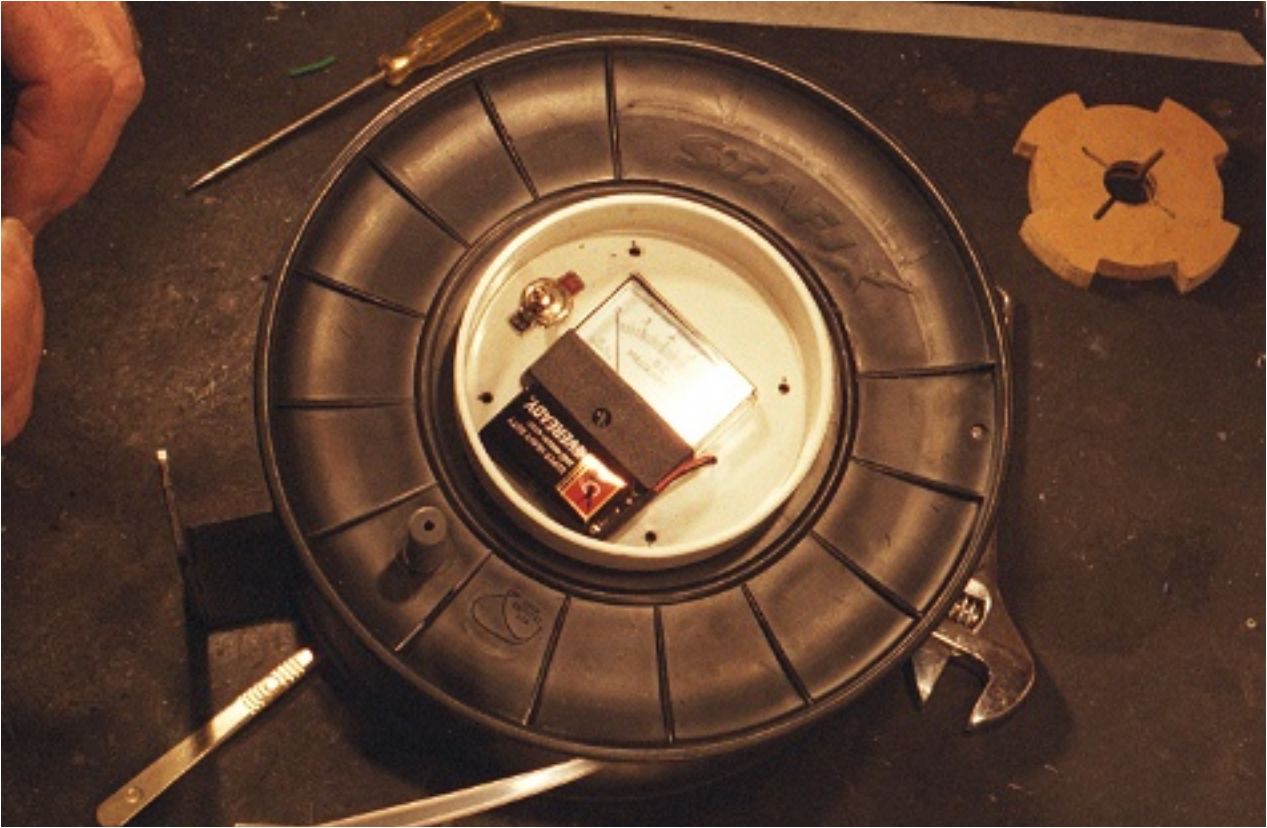

Figure 42. Meter cap into reel hub.



Figure 43. Screw Meter cap to reel.

Step 6 Ribbon assembly

6.1 *Wrap electrical tape around reel hub to cover screw heads.*



Figure 44. Wrap antennae ribbon around reel hub.

6.2 *Wind antennae ribbon onto reel*

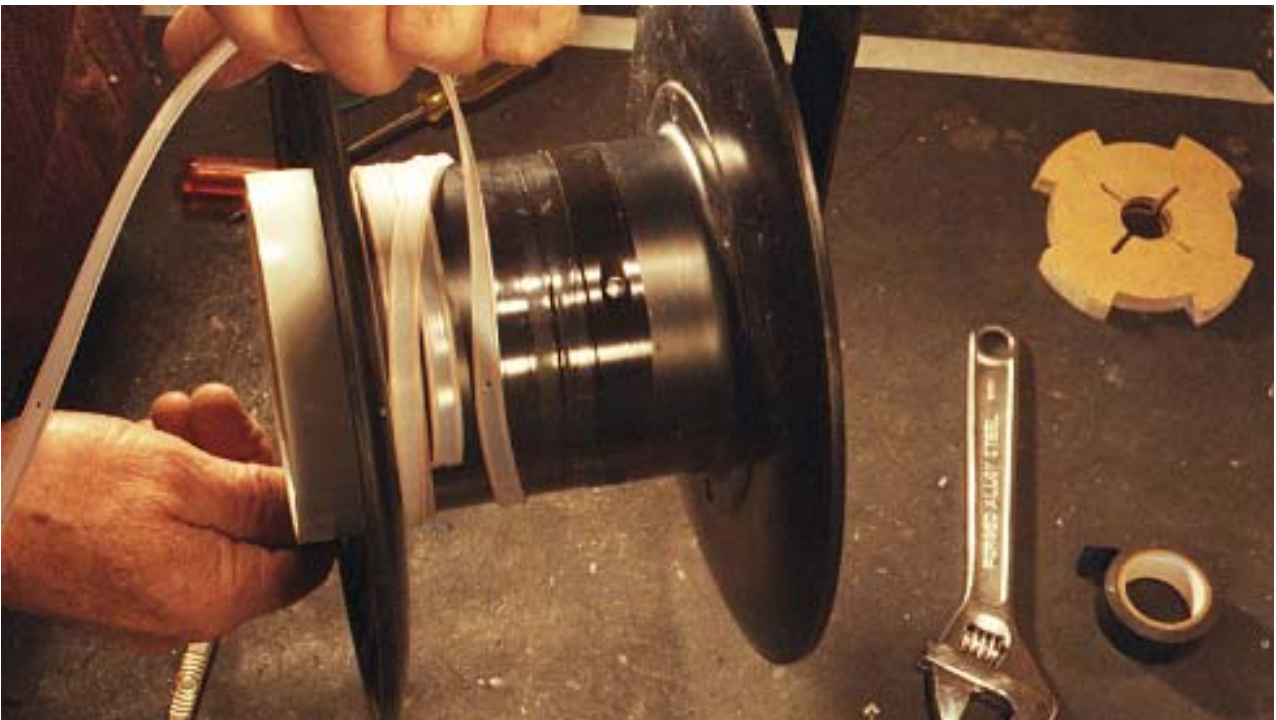

Figure 45. Wrapping antennae ribbon around hub.

6.3 Attach copper sheathing onto antennae ribbon end

Remove 5 mm of the web from the ribbon. Cut 2 mm of the web from the ribbon end and solder a bead on the end of each wire. Partially flatten the 100-mm-long copper tube and slip over the ribbon cable. With 12 mm of ribbon exposed below the copper tube, flatten the tube to a sheath. Wrap the copper sheath in electrical tape to hold in place. The copper adds weight to ribbon and provides more vertical measurement without tape curling in the well. A second copper sheath can be added (shown already wrapped in black electrical tape against white ribbon on reel in Figure 46).



Figure 46. Attach copper sheath to antennae ribbon end.



Figure 47. Wrap electrical tape around copper sheath.

6.4 Mark antennae ribbon for length

Start at the solder beads on the ribbon and punch a 2-mm hole at every 100 mm in the ribbon centre. Punch two side-by-side holes midway between even metres, such as for 0.5 m, 1.5 m, etc. Write "1" in permanent felt pen next to the 1-metre hole. Repeat this process for the tape length.

For making several water-level meters, make a jig to speed up ribbon calibration. Drill 11 2-mm holes--100-mm apart--into a piece of light angle iron (or wood), 1.5m long. Insert a 2-mm screw (or nail if using wood) at the first hole at the end the iron. Mark and label, with permanent marker, every 100-mm along the side of the iron bar. Measure and punch a centred hole at 1 m from the ribbon terminus. Then put the 1-m ribbon hole over the pin and stretch the ribbon terminus down the iron/wood and lightly clamp in place. While held in place, punch through the tape with a centre punch. Move the ribbon at the 500-mm marks to make two punches, side-by-side. Punch the full tape length.



Figure 48. Mark antennae ribbon length increments.



Figure 49. Marked antennae ribbon.

Step 7 Completed water-level meter



Figure 50. Completed water-level meter.
